

BUSTER+PUNCH

LONDON

ELECTRICITY

DUMMY DIMMER MODULE / RETRACTIVE / PUSH ON OFF

CDM-023405

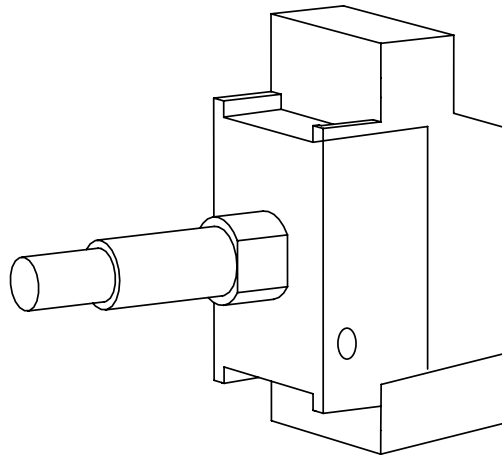

TECHNICAL SPECIFICATION

Retractive Dummy Dimmer (Push to make)

230V ~ 50Hz

Max Load 300W

*Compatible with Retractive Multi-Location Dimmer and Smart Modules with retractive switch inputs.

IMPORTANT!

This product must be installed by a qualified professional. Turn off the power at the breaker prior to installing this product.

WARRANTY INFORMATION

The Warranty Period of Two (2) years from the date of the original purchase.

BUSTERANDPUNCH.COM

L0227



OVERVIEW

Thank you for choosing Buster and Punch. This switch is designed for Retractive dimmers and can be used to switch almost all lighting loads. It is a Retractive Dummy dimmer module for use with dimmable loads for switching only to coordinate with other retractive dimmer switches. Use only on an electricity supply of 230 volts AC.

IMPORTANT: READ ALL SECTIONS BELOW BEFORE INSTALLING THIS SWITCH.

HEAD OFFICE / UK, Sand Martin House, Bittern Way, Peterborough, PE2 8TY United Kingdom.

LOADING

Maximum load for Switch modules is 6A.

THIS SWITCH IS SUITABLE FOR



Pairing with our Retractive Dimmer Switch (CDM-023405)

THIS SWITCH IS NOT SUITABLE FOR



Dimming (switch only)

FREQUENTLY ASKED QUESTIONS

For FAQs, please visit: <https://www.busterandpunch.com/eu/support>

GUARANTEE

For FAQs, please visit: <https://www.busterandpunch.com/eu/support>

In case of any defect, return the dimmer to our service department. Buster and Punch undertake to repair or replace, at its discretion, goods which have become defective within 10 years of purchase, solely as a result of faulty materials and workmanship, provided that:

- The unit has been correctly fitted according to the instructions and has not been used with an incompatible load, fluorescent tubes, or overloaded beyond its rating, and has only been used on a 200-250V a.c. power supply.
- The dimmer module has not been tampered with or taken apart. However, for your convenience, it is fine to remove a faulty dimmer module from multi-gang dimmers by pulling off the knob and unscrewing the nut under the knob. You will still be able to use the remaining modules working while we service your faulty module.
- The unit is securely packed and safely returned to the address listed in the overview section above, together with a letter stating the guarantee registration number below, the date and place of purchase, your contact details and return address, the type and wattage of the lighting or other load being controlled and the details of the fault. This guarantee states Buster and Punch's entire liability, which does not extend to cover consequential loss, damage or installation costs arising from a defective product. The guarantee does not apply to problems arising from any incompatibility between your lamps and the dimmer switch. This guarantee does not in any way affect the statutory rights of the purchaser and is offered so that you may have the benefit of our technical facilities.

In many cases, products don't need replacing, so for further information and help with troubleshooting, see our FAQ page at <https://www.busterandpunch.com/eu/support>, or contact our Customer Services by calling +44 (0)1293 223333 or create a support ticket at <https://www.busterandpunch.com/eu/support>

RECYCLE:

Recycling services for end-of-life electrical products should be offered by your local authority. Recycling services for metal faceplates may also be available in your locality.



FITTING YOUR DIMMER

Read the instructions below carefully. Incorrect installation may damage the dimmer beyond repair. In case of any doubt or difficulty consult a qualified electrician.

1. Switch off at the mains, then remove the existing switch and disconnect the wiring from the switch terminals at the rear, taking note of the present wiring of the switch and the marking on the terminals. Where there are two or more wires together in the old switch, they must be kept together in the switch.
2. Ensure that any wall box is free of plaster lumps or projecting screw heads. Switches on single-sized plates can be fitted to wall boxes having 60.3mm screw fixing centres and those with double sized plates to wall boxes with 120.6mm fixing centres. Most models can be fitted into a box with a minimum depth of 25mm. A box having 4 fixing lugs cannot be used without modifying it. The top and bottom lugs must be broken off or bent flat.
3. To connect the wiring for 1-way or 2-way circuits refer to the diagrams below. Take care that no bare wires project out of the terminals. Keep wires together in a terminal if they were together in your old switch.
4. Switches having a metal front plate must be earthed by means of the earthing point on the plate.
5. After connecting the wires screw the switch gently into the wall box so that the front plate is not distorted or cracked. Do not trap the wiring between the rear of the dimmer and the back of the wall box.
6. Once installation is complete. Switch on the mains supply and switch on.

WARNING!

DO NOT APPLY PRODUCTS WITH METAL FACEPLATES DIRECTLY TO FRESHLY PLASTERED OR DAMP SURFACES AS PRODUCT MAY TARNISH. IF IN DOUBT, USE POLYTHENE AS A TEMPORARY GASKET TO PROTECT THE PRODUCT. DO NOT USE MASKING TAPE ON METAL FACEPLATES.

WARNING!

THE SWITCH IN THIS PRODUCT IS RATED AT 6A. CHECK THE IN-RUSH CURRENT FOR LED BULBS OR DRIVERS DOES NOT EXCEED 6A BEFORE CONNECTING. FIT INRUSH CURRENT LIMITERS WHERE NECESSARY.

Connect the wires as shown in appropriate wiring diagrams. Use green/yellow sleeving on earth conductors that are not insulated. Ensure terminals are properly tightened and no bare wire is visible. Push back unit into moulding box making sure conductors are not trapped.

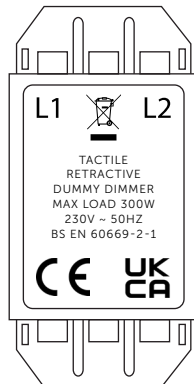

1



BEFORE COMMENCING WORK, ISOLATE THE MAINS POWER SUPPLY AND REMOVE THE FUSE BOX OR SWITCH OFF THE CIRCUIT BREAKER IN CONSUMER UNIT.



MULTIPLE LOCATION DIMMING

How to dim from multiple locations using Buster + Punch Retractive Dummy Dimmer (push to make) Switch : Press Retractive Dummy Dimmer to switch lights ON/OFF. Press and hold knob to increase brightness, release, press and hold to decrease brightness.

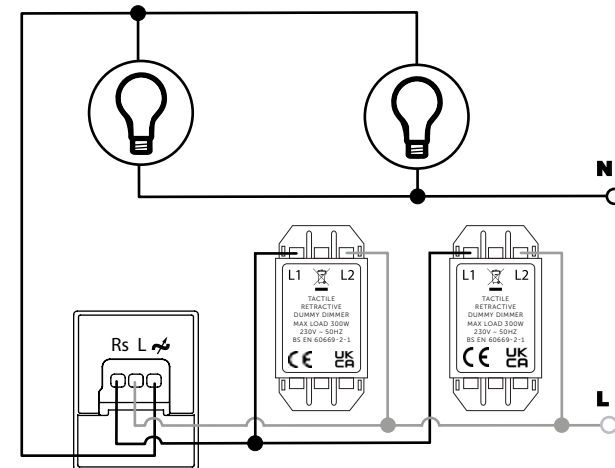

The Multipoint Dimmer must always be connected to the LINE side of the load. You can have up to 10 retractive switch's or retractive dummy dimmers connected to your dimmer to control from multiple locations.